



- TASTE THE DIFFERENCE -

MODEL CS700

Designed to serve a premium hand spun milkshake, the dispense head mounted mixer allows you to blend as many flavours as required. If you want to serve the highest quality milkshakes—this is the machine for you.

The Electro Freeze Advantage

- **Exclusive Beater Design** gently blends, reducing agitation and maintaining product quality and consistency
- **Consistency control** designed to dispense the finest frozen product available
- **Air Filter** washable filter keeps the condenser clean
- **Compact Design** with small footprint
- **Experience Tells** Electro Freeze has been manufacturing quality frozen treat machines since 1929.
- **All New Electro Freeze Milkshake Machines** are supplied in the U.K. with a **One Year Parts & Labour Warranty**.

Optional

- **Top Air Discharge Chute** the top air discharge chute on air cooled models allows units to be set side by side and air flow to be diverted up.
- **Cart Unit** as shown (CS700/F)

HAND-SPUN MILKSHAKE MACHINE COMPACT SERIES



*Available as a floor
Standing Machine
(CS700/F)*

electrofreeze.com

FOR MORE INFORMATION CONTACT
023 8062 9520 • info@electrofreeze.co.uk



CS700 Shake Freezer

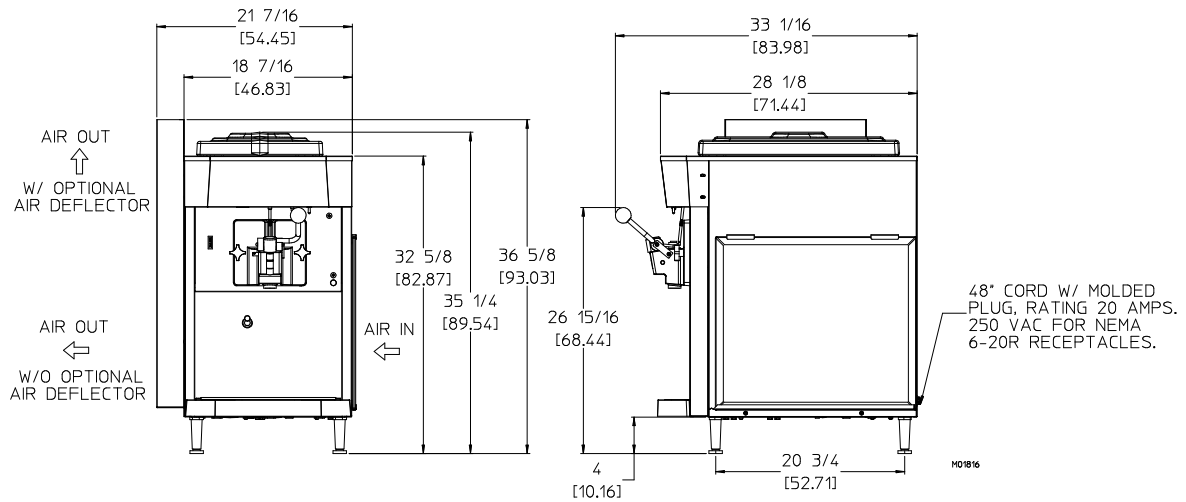

MODEL CS700 SPECIFICATIONS

Due to continual product improvements all specifications are subject to change without notice.

Weights	kgs.	
Net	134	
Crated	176	
	cu.m.	
Volume	1.12	
Dimensions	cm	
Width	47	
Depth	72	
Height	90	
Electrical		
	Amps	
220-240/50/1 Air	12	2.4kW

Warranty

All new Electro Freeze Milkshake Machines are supplied in the U.K. with a One Year Parts & Labour Warranty.

Electrical

A dedicated 16 Amp electrical connection is required.

Beater Motor

One, 1/2 hp.

Refrigeration Systems

One, 8,000 Btuh. R452a.

Btuh may vary depending on compressor used.

Air Cooled

7.5cm air space required on both sides and the rear panel for proper air circulation.

Mix Hopper Capacity: 18.8 Litres

Freezing Cylinder Capacity: 7.1 Litres

Electro Freeze Sales (UK)

Citygrove Trading Estate, Woodside Road
 Eastleigh, Hampshire, SO50 4ET (U.K.)
 Phone (023) 8062 9520 International +44 23 8062 9520
 E-mail: info@electrofreeze.co.uk • www.electrofreeze.co.uk

