



- TASTE THE DIFFERENCE -

## MODEL 99T-RMT

This is our top of the range, twin flavour plus twist, pressurised (pump fed) soft serve machine. Whether it is for soft ice cream or frozen yogurt it produces the highest quality, most consistent and profitable product you can serve.

### The Electro Freeze Advantage

- **Patented Mix Transfer System\*** simplest and most reliable pressurised system available.
- **Adjustable Overrun** to suit the mix being served.
- **Flexible Mix Holding System** pumps directly from bag in box or from mix tanks.
- **The Finest Frozen Product**, consistently the best frozen product available, smooth, creamy and profitable.
- **Self Closing Handles** prevents mess and eliminates waste.
- **Adjustable Dispense Rate** set to meet your specific dispensing speed and volume requirements
- **Exclusive Beater Design** with demountable blades which can easily be replaced.
- **Energy Conservation Mode** reduces energy cost and holds product safely during non-business hours.
- **Superior Low Temperature Refrigeration System** provides the best in class production and product quality.
- **Experience Tells** Electro Freeze has been manufacturing soft serve machines in the U.S.A. since 1929.
- **All New Electro Freeze Machines** are supplied in the U.K. with a **Three Year Parts & Labour Warranty.**

\*U.S. Patent #5,349,825

## PRESSURIZED SOFT SERVE MACHINE

**Freedom 360° Series  
2 Flavours & Twist**



[electrofreeze.com](http://electrofreeze.com)

**FOR MORE INFORMATION CONTACT**

**(023) 8062 9520 • [info@electrofreeze.co.uk](mailto:info@electrofreeze.co.uk)**

# 99T-RMT Soft Serve Freezer

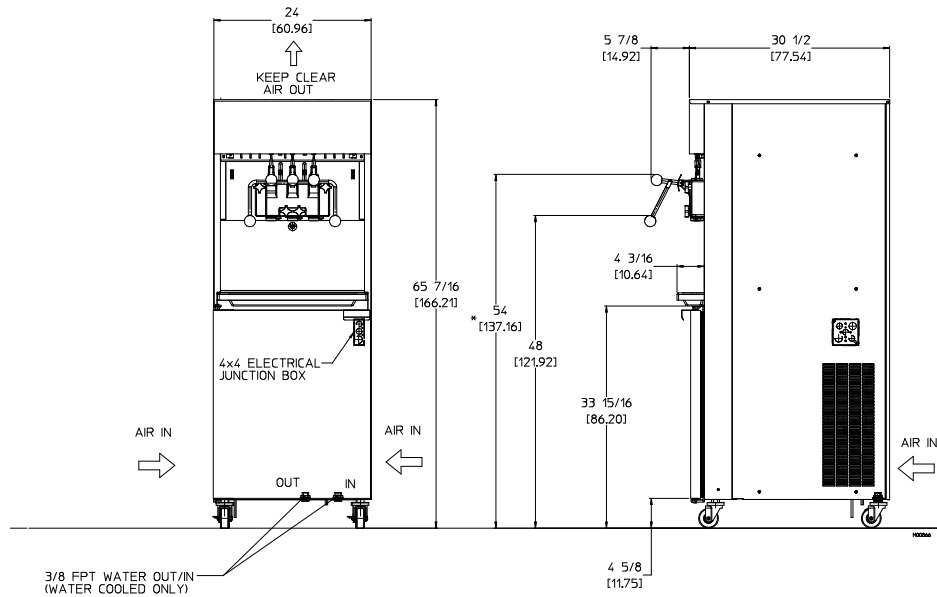

## MODEL 99T-RMT SPECIFICATIONS

Due to continual product improvements all specifications are subject to change without notice.

Weights	kgs.
Net	341
Crated	364
Volume	cu.m.
Volume	1.65
Dimensions	cm.
Width	61
Depth	78
Height	166
Electrical	Supply Required
3 Phase 400/50/3	20 Amp (per phase)
<i>Check nameplate for exact electrical data.</i>	

### Electro Freeze Sales (UK)

Citygrove Trading Estate, Woodside Road  
 Eastleigh, Hampshire, SO50 4ET (U.K.)  
 Phone (023) 8062 9520 International +44 23 8062 9520  
 Email: info@electrofreeze.co.uk  
 www.electrofreeze.co.uk

### Warranty

All new Electro Freeze Soft Serve Machines are supplied in the U.K. with A Three Year Parts & Labour Warranty.

### Electrical

A dedicated electrical connection is required. Manufactured to be permanently connected. See the electrical chart for the proper requirement.

### Beater Motors

Two x 2 hp.

### Refrigeration Systems

One, 12,000 Btuh. R452a.  
 Separate Cabinet Refrigeration, One, 1200 Btuh, R134a.  
 Btuh may vary depending on compressor used.

### Air and Water Cooled

15 cm air space required at rear panel or both side panels and 50 cm air space above unit for proper air circulation.

**Mix Tank Capacity:** 20 litres x 2

**Freezing Cylinder Capacity:** 3.5 litres x 2

\*48" handle extension kit is available for ADA compli-

